

2+5-Wire Overfill Sensors

FEATURES AND BENEFITS

Optic overfill sensors detect the presence of liquid at a preset level. The new Civacon Universal 2+5-Wire Sensor is fully compatible with all our current Sensors and Monitors, as well as all industry standard signal formats. These new Universal Sensors feature an exclusive, digital electronic circuitry design that will work directly with 2&5-wire loading racks when wired directly to a blue "optic" socket, as well as with all Onboard Monitors like our Liberty™.

The new Civacon Universal 2&5-Wire Sensors are a direct replacement for our existing Liberty™ optic sensors. With their universal industry compatible signal format, they are a perfect choice for all of your overfill detection sensor applications. All of the features & benefits of these new sensors are also available in our new 2-wire sensor version as well (see separate data sheet).



- **Product Number Materials**
- **1552 & 1112E-XXXX Sensor Cap** - Glass Filled Nylon
- **Cap O-ring seals** - Silicone
- **Sensing Length Adjustability**
Sensor Housing - Aluminum
- **Locking Nut** - Plated Steel
- **Product Range** Sensor Shaft - Aluminum
- **Viscosity** of less that 1000 SSU Prism
- **Snap Ring** - Stainless
- **Approvals** Europe (ATEX)
- **Weight 1.15 lbs.** (0.521 kg)
- **Operating Temperature** -40° F (-40° C) to 160° F (71.1° C)
- **Storage Temperature** -70° F (-56.6°) to 280° F (137.7° C)
- ****Special length sensors** are available upon request
- **In accordance** with EN13922
- **Intrinsically safe operation**
- **ATEX** certified
- **Continuously** self checking

CERTIFICATES



2-Wire, ATEX, EN13922



5-Wire, ATEX, EN13922

SPECIFICATIONS

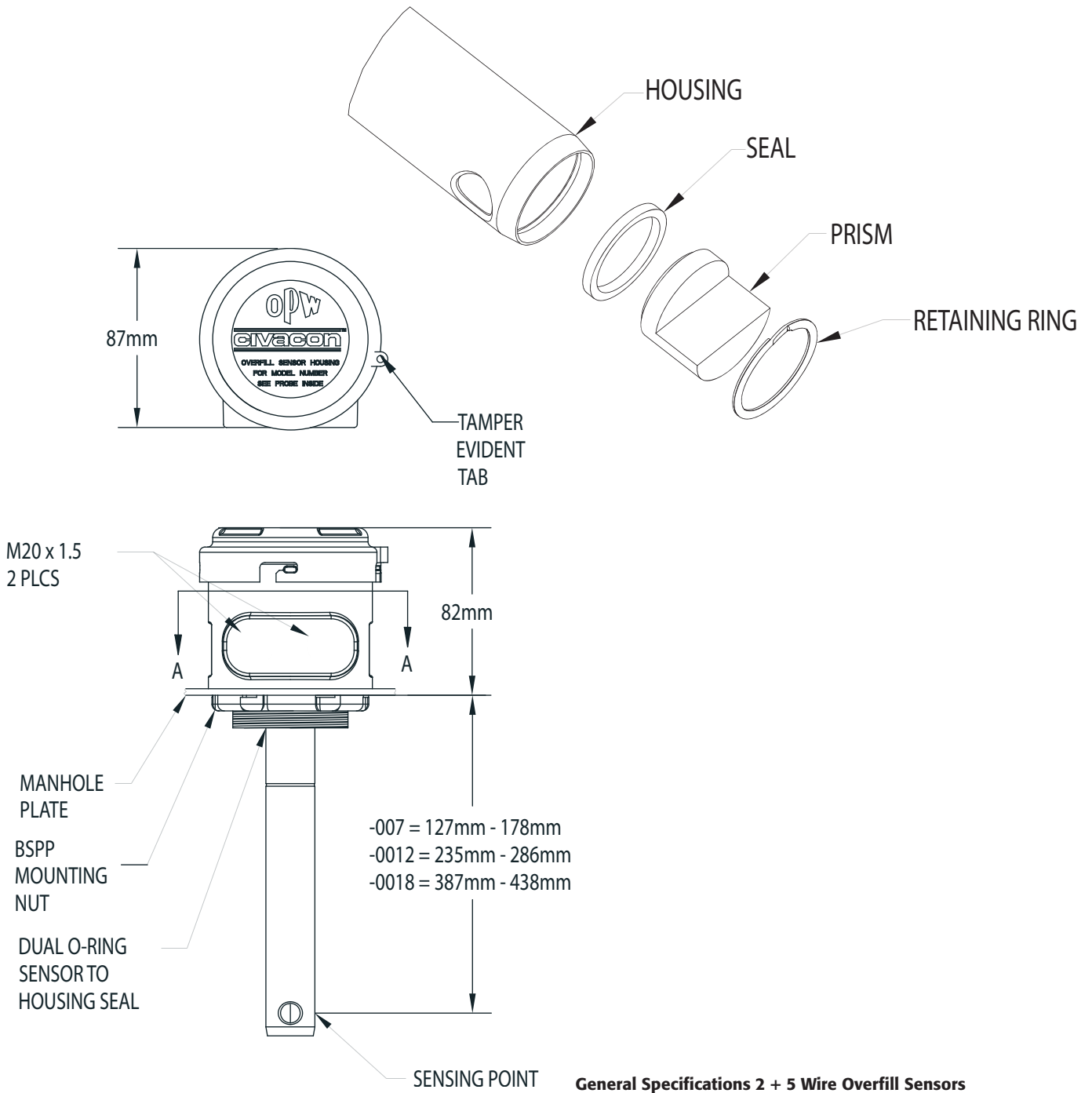

General Specifications 2 + 5 Wire Overfill Sensors

■ Zone specification	Zone 0
■ Working Temperature	-20°C to +70°C
■ Signals	Intrinsically safe
■ Weight	1.15 lbs (0,521 kg)

All dimensions are in mm

SPARE PARTS

Item	Part Number	Description	QTY
1	1301-0018GE	Replacement optic overfill sensor no housing 18" probe	1
2	H52840	Housing machined	1
3	H52936M	Cap probe housing with u-cup	1
4	H52301M-1112E	Label sensor 1112ge	1
5	H52842M	O-ring 2-021 buna	2
6	H52595M	Plug, pipe, rehab kit m20x1.5	1
7	H52477M	Lock ring	1
8	H52898M	Screw	1
9	H52845M	Spring	1
10	H52844M	O-ring	1

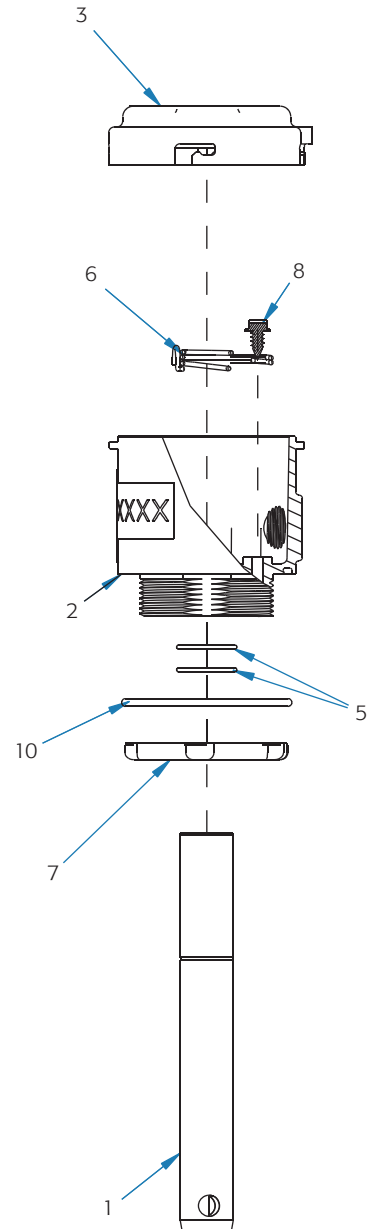
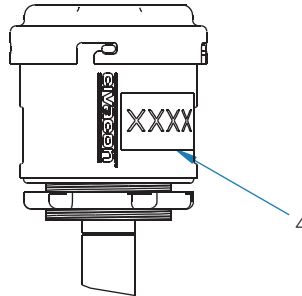

RELATED PRODUCTS

Art. number	Description
4103-series	6-Pin Optical Socket
4403-series	10-Pin Optical/Thermistor Socket
2100E-L30	30m 5-Wire straight cable conform EN13922
EL05116	Cable Gland blue
EL00001E	Ground Bolt
1552-series	2-Wire Optic Quick Start Sensors
1000R	2-Wire Optic Bottom Retain Sensor
1391-1391	Optic System Tester
1398E-X001	Truck tester, 4-J-slotted, black plug
1397E-X001	Truck tester, 3-J-slotted, blue plug
T400-series	20" Manhole Cover
3205E	On-board Monitoring System
SCS-300	Sealed Parcel Delivery System

ORDERING SPECIFICATIONS

1112-007E	Adjustable 5-wire optic sensor with 2-inch BSP housing 7-inch shaft length
1112-0018E	Adjustable 5-wire optic sensor with 2-inch BSP housing 18-inch shaft length
1552-007E	Adjustable 2-wire optic sensor with 2-inch BSP housing 7-inch shaft length
1552-0018E	Adjustable 2-wire optic sensor with 2-inch BSP housing 18-inch shaft length

